

## FUNCTIONS OF VALVE POSITIONS

Valve Position	Function
FILTER	Normal Filtration and Vacuuming
BACKWASH	Cleaning Filter by reversing the flow
RINSE	Used after backwash to flush dirt from valve
WASTE	By-passes filter, used for vacuuming to waste or lowering water level
RECIRCULATE	By-passes filter for circulating water to pool
CLOSED	Shuts off all flow to filter or pool

### FILTER

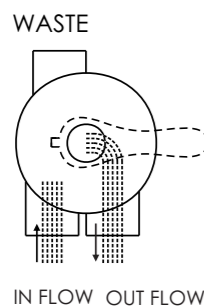

### WASTE

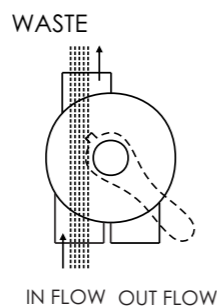

### CLOSED

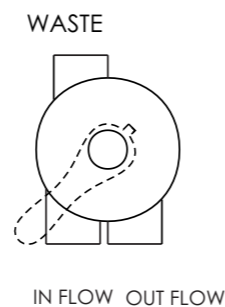

### BACKWASH

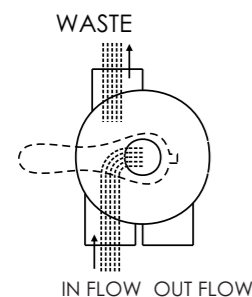

### RINSE

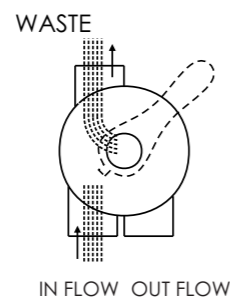

### RECIRCULATE

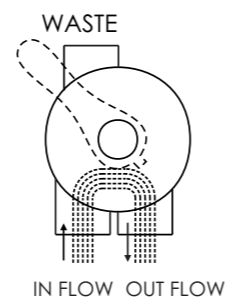

### GENERAL

- 1) Pipe tap boss provided for optional influent pressure gauge.
- 2) SERVICING VALVE (Stop pump, close gate valve in suction & discharge before proceeding):
  - a) Set handle in filter position.
  - b) Remove cover screws.
  - c) Lift cover and key assembly out.

### TO ASSEMBLE:

- 1) Place valve key so that wedge opening is at TOP port (handle in Filter psn.). Flat edge of cover screw lug should align with flat edge of body screw lug.
- 2) Position cover O'Ring.
- 3) Secure assembly to body with cover screws. Tighten cover screws evenly and alternately. Do not over-tighten.

### WARNING

- ⚠ THIS FILTER OPERATES UNDER HIGH PRESSURE. WHEN ANY PART OF THE CIRCULATING SYSTEM (e.g., CLAMP, PUMP, FILTER, VALVES, ETC.) IS SERVICED, AIR CAN ENTER THE SYSTEM AND BECOME PRESSURIZED. PRESSURIZED AIR CAN CAUSE THE LID OR VALVE TO BE BLOWN OFF WHICH CAN RESULT IN SEVERE INJURY, DEATH, OR PROPERTY DAMAGE.
- ⚠ TURN PUMP OFF BEFORE CHANGING VALVE POSITION.
- ⚠ TO PREVENT DAMAGE TO THE PUMP AND FOR PROPER OPERATION OF THE SYSTEM, CLEAN PUMP STRAINER AND SKIMMER BASKETS REGULARLY.
- ⚠ DO NOT UNSCREW SCREWS OF FLANGE CLAMP WHILE PUMP IS RUNNING.

## Models: S450 / S500 / S650 / S700

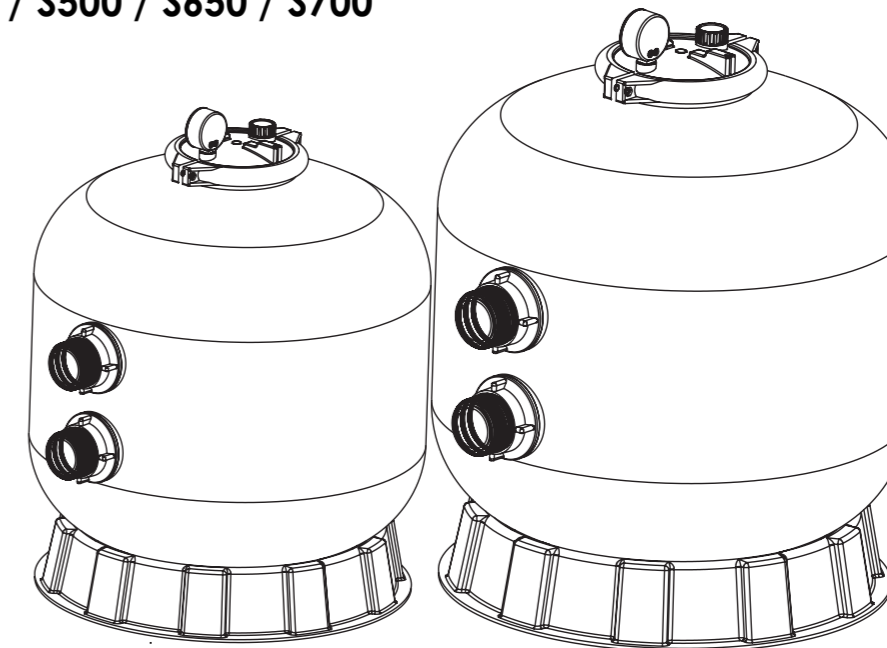

### FUNCTION

The filter uses special filter sand to remove dirt particles from pool water. The filter sand is loaded into the filter tank and functions as the permanent dirt removing media. When the control valve is in the FILTER position, the pool water which contains suspended dirt particles, is pumped through your piping system and is automatically directed by the patented filter control valve to the top of the filter tank. As the pool water is pumped through the filter, dirt particles are trapped by the sand bed, and filtered out. The cleaned Pool water is returned from the bottom of the filter tank, through the control valve and back to the pool through the piping system. This entire sequence is continuous and automatic and provides for total recirculation of pool water through your filter and piping System.

After a period of time the accumulated dirt in the filter causes a resistance to flow, and the flow diminishes. This means it is time to clean your filter. With the control valve in the BACKWASH position, the water flow is automatically reversed through the filter so that it is directed to the bottom of the tank, up through the sand, flushing the previously trapped dirt and debris out the waste line. Once the filter is back-washed of dirt, set control valve to RINSE position and run pump for about 1/2 to 1 minute, and then to filter, to resume normal filtering.

**NOTE: Turn pump off before changing valve position.**

### INSTALLATION

Only simple tools (screwdriver and wrenches), plus pipe sealant for plastic adapters, are required to install and service the filter.

- 1) The filter should be placed on a level concrete slab, very firm ground, or equivalent. Position the filter so that the piping connections, control valve are convenient and accessible for operation and service.
- 2) Loading the sand media. Filter sand media is loaded through the top opening of the filter.
  - a) Loosen the clamp lock, remove the transparent lid.
  - b) Cover the diffuser with the block sand cover.
  - c) We recommend: add a half tank of water in the tank, then to fill with sand, so that we can protect the bottom of the filter from the damage caused by excessive shock.
  - d) Add the right amount of sand, sand surface to smooth.

- 3) Replace filter coping (with O'ring in place).
  - a) Mount the O-ring for filter neck, covered with transparent lid.
  - b) Lock the clamp lock, pay attention to the clamp lock clip on both sides are even.
  - c) Install the pressure gauge and air release valve to the transparent lid.
  - d) Connect the pump outlet to the valve inlet, a preliminary combination has completed.
- 4) Make return to pool pipe connection to control valve opening marked RETURN and complete other necessary plumbing connections, suction lines to pump, waste, etc.
- 5) Make electrical connections to pump per pump instructions.
- 6) To prevent water leakage, be sure all pipe connections are tight.

### MAIN DIMENSION

**DIMENSION TABLE**

Model	High A mm	Diameter B mm	Valve inch	Sand kg
S450	730	455	1.5 "	45
S500	770	535	1.5 "	85
S650	850	635	1.5 "	145
S700	960	710	1.5 "	210

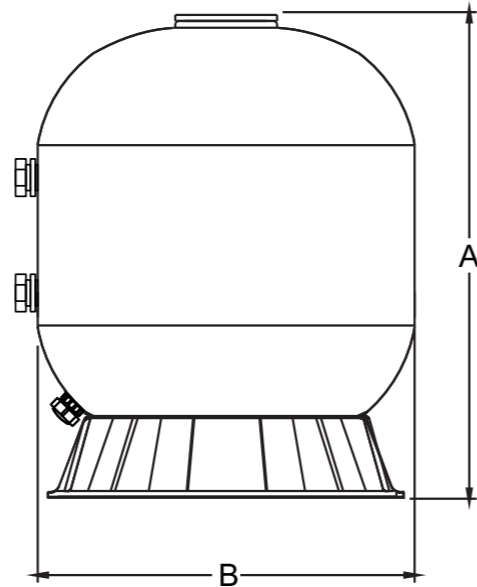

### INSTALL/START-UP OF FILTER

- 1) Be sure correct amount of filter media sand is in tank and that all connections have been made and are secure.
- 2) Depress control valve handle and rotate to BACKWASH position. (To prevent damage to control valve seal, always depress handle before turning.)
- 3) Prime and start pump according to pump instructions (be sure all suction and return lines are open), allowing the filter tank to fill with water. Once water is flowing out of the waste line, run the pump for at least 1 minute. The initial back-washing of the filter is recommended to remove any impurities or fine sand particles in the sand media.
- 4) Turn pump off and set valve to RINSE position. Start pump and operate until water in sight glass is clear, about 1/2 to 1 minute. Turn pump off and set valve to FILTER position and restart pump. The filter is now operating in the normal filter mode, filtering dirt particles from the pool water.
- 5) Adjust pool suction and return valves to achieve desired flow. Check system and filter for water leaks and tighten connections, bolts, nuts, as required.
- 6) Note the initial pressure gauge reading when the filter is clean. (It will vary from pool to pool depending upon the pump and general piping system.) As the filter removes dirt and impurities from the pool water, the accumulation in the filter will cause the pressure to rise and flow to diminish. When the pressure gauge reading is 1.5 bar, higher than the initial "clean" pressure you noted, it is time to backwash the filter (see BACKWASH under filter and control valve functions).

### REPLACEMENT PARTS OF FILTER

Key No.	Part No.	Description	Qty
1	89010701	Air Release Valve with O-ring	1
2	06011032	Maximum 40PSI Indication, Stainless Steel Casing	1
3	01201022	Lid (Transparent)	1
4	01271010	Clamp Lock	2
5	03021035	M6 Nut	1
6	03011095	Screw	1
7	02011134	O-Ring for Filter Neck	1
8	89010706	Filter Tank for S450	1
8	89010705	Filter Tank for S500	1
8	89010704	Filter Tank for S650	1
8	89010703	Filter Tank for S700	1
9	02011003	O-Ring for 1.5" adaptor	2
10	88280811W	6 Way 1.5" Valve with Piping Kit, 1.5" union set x 3 and pressure gauge (White)	1
11	89010708	The Inner Tank System for S450	1
11	89010709	The Inner Tank System for S500	1
11	89010710	The Inner Tank System for S650	1
11	89010711	The Inner Tank System for S700	1
12	01111046	1.5" Tank System Support	1
13	01172007	Laterals (115mm)	8
13	01172008	Laterals (126mm)	8
14	89010107	Water Drain Set	1
15	01111059	16-21inch Filter Base	1
15	01111062	21-28inch Filter Base	1

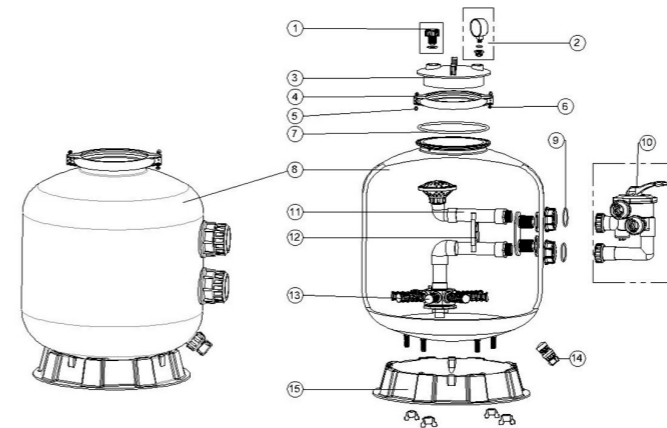

### REPLACEMENT PARTS OF MULTIPOINT VALVE

Key No.	Part No.	Product Description	Qty
1	01013002	Handle (Small)	1
2	03018008	Pin for Handle	1
3	01181001	Washer for Handle	1
4	89281203	M6x25 Screw with Nut for Camber Lid	6
	89280107	M6x30 Screw with Nut for Standard Lid	6
5	01051010	1.5" Side Mount Valve Standard Lid (White)	1
6	02011022	O-Ring for 1.5" Valve Rotor	2
7	01181002	Washer for Spring	1
8	02011002	O-Ring for 1.5" Valve Lid	1
9	03014001	Spring for 1.5" Side Mount Valve	1
10	01021001	1.5" Valve Rotor	1
11	02311002	Spider Gasket	1
12	01051021	1.5" Side Mount Valve Bottom Body (White)	1
13	01111048	Connector for Pressure Gauge/Stopper	1
	02011139	O-ring	1
14	89021303	Drain Plug with O-ring	1
15	06011032	Oil Pressure Gauge with O-ring (40Psi)	1
16	02020013	O-Ring	5
17	01051022	1.5" Union Tale (White)	1
18	01013017	1.5" Union Nut (Black)	5
19	89280104	Sight Glass with O-Ring	1
20	01051023	1.5" Side Mount Valve Plug (White)	1
21	01051193	1.5" Elbow Tube (White) 120mm	1
22	01171002	1.5" Union Adaptor (Metric)	1
23	01051013	1.5" Connector with External Thread (White)	3
24	02011003	O-Ring $\phi 59 \times \phi 53 \times \phi 3$	5
25	01171153	1.5" Union Adaptor	3

